

Press Machine Safety Guide

(For employers and employees)



This safety guide is an English translation of Japanese safety guide based on Japanese laws and regulations.
Please comply with your country's laws and regulations if you are outside of Japan.



Eighth edition
April 2020

Preface

This safety guide provides employers and employees with important safety information they should know when they purchase AMADA press machines.

Safety information for using press machines is also available in the operator's manuals of press machines and the warning labels affixed to the press machines. Before you use the machine, fully understand all of these pieces of safety information.

The safety guide contains information on residual risks of the machine. Fully recognize hazards associated with machine installation, workpiece and die setup, machine operation, inspection, cleaning and maintenance, and other tasks. On your own responsibility as employer, take safeguarding measures to suit the environment of your shop and the method of using your machine. Also conduct safety and health education for your operators.

The Industrial Safety and Health Act states that employers must take machine safeguarding measures.

(See "Responsibilities of employer" on the next page.)

Several examples of preventive measures are introduced here. Safeguarding devices recommended by AMADA are offered as options. Please study and adopt them.

For machine safeguarding procedures, etc., refer to "Guidelines for the Comprehensive Safety Standards of Machinery" published by the Ministry of Health, Labour and Welfare (LSB Notification No. 0731001, revised on July 31, 2007).

To see the guidelines, go to the website of the Japan Advanced Information Center of Safety and Health (<https://www.jaish.gr.jp>), click the "Laws, Regulations and Notifications" button, enter "No. 0731001", and find the LSB Notification No. 0731001.

When you retrofit safeguarding devices to your already installed machine, you may have to modify the machine and its controls. When you study what safeguarding devices to adopt, please contact AMADA.

Responsibilities of employer

The Industrial Safety and Health Act (hereinafter referred to as Act) and Ordinance on Industrial Safety and Health (hereinafter referred to as Ordinance) mainly impose the following duties on employers who have their workers use machines, in order to reduce industrial accidents.

(1) Notifying of plans

- Notify the Labour Standards Office of plans.

Notify the Labour Standards Office of plans to install, relocate or alter machines, etc.
(Article 88 of Act and Article 85 of Ordinance)

Notify the Labour Standards Office of such plans, have the plans checked for safety, and receive guidance about the plans.

- Notify the competent government office of a specified facility and apply to the competent government office for permission to use the specified facility.

If the specified facility falls under the provisions of the Noise Control Act, the Vibration Control Act and the environmental conservation ordinance of the competent local government, notify the competent environmental conservation contact office of the specified facility.

Since the notification duties, control values, etc., vary from region to region, check the details at the competent environmental conservation contact office.

(2) Investigating hazardousness and harmfulness

Investigate the hazardousness and harmfulness of tasks and duties (or assess the risks of tasks and duties). Also, make efforts to take necessary measures to prevent hazards to workers and prevent their physical disorders. (Article 28-2 of Act)

For data concerning residual risks peculiar to specific machines and required to perform risk assessment, contact AMADA.

(3) Preventing hazards

Take appropriate safeguarding measures to ensure the safety of press operators. (Article 20 of Act and Article 131 of Ordinance)

Protect workers from hazards from machines, hazardous materials, and electricity and other energy sources.

Take measures to prevent the body parts of workers from entering the hazardous area.

(4) Appointing chief operator

Appoint a qualified chief operator. (Article 14 of Act and Article 16 of Ordinance)

In a workplace with five or more power presses, appoint a chief operator from among workers given technical training.

(5) Conducting safety and health education

Conduct safety and health education to workers who operate the machine for the first time. (Article 35 of Ordinance)

Provide special education to workers who change or adjust dies. (Article 36 of Ordinance and Article 3 of Rules on Special Safety and Health Education)

(6) Inspecting before start of day's work

Inspect the machine before the start of the day's work. (Article 136 of Ordinance)

Try to find equipment failures and faults as soon as possible. If a problem is found, repair it or take any other necessary measure to prevent an accident.

(7) Conducting special voluntary inspection

Conduct legal inspection by qualified personnel once or more per year. (Article 135 of Ordinance)

Repair any problems found by the inspection, and file the inspection results and repair records.

1. Operating environment and installation space of press machine

1-1. Operating environment

Use the press machine in the following environment.

If used outside the operating environment in the table below, the machine and safety devices will not function properly, causing a fire, failure, malfunction, or damage, which may lead to personal injury.

Operating environment

Input power supply	Voltage:	3-phase 200 V/ 220 V \pm 10%
	Frequency:	50 Hz/60 Hz \pm 1 Hz
	Grounding:	● TP, TPW, TPWL, PDL series Class D (Class 3) Inverter supporting item when an earth leakage circuit breaker is used for inverter specification machine ● SDE, SDEW, SWE Series Independent grounding Class C (Special Class 3) Inverter supporting item when an earth leakage circuit breaker is used for inverter specification machine (Recommended sensitivity current: 100 mA or more)
Air supply:	Supply pressure	0.5 MPa or more (dry and clean compressed air without dust and drain)
Operating ambient temperature:		+5 to +40°C (no freezing)
Operating ambient humidity:		20 to 90% (no dew condensation)
Atmosphere:		No salt and conductive dust No corrosive gas or flammable gas No splash of water, oil, chemicals, etc. No affect by electrical noise No direct sunlight and wind from air conditioner
Installation base:	Tolerance:	70 kN/m ² or more The base dimensions differ depending on the model and specifications of the machine. For details, refer to the separate materials.
Caution when connecting external devices:		When connecting an external device, incorporate a protective circuit such as a surge absorber or the like.

1-2. Installation space

When installing a machine, secure adequate maintenance space around the machine.

If the press machine cannot be inspected and maintained adequately, the machine and safety devices will not function properly, which will impair safety.

The figure below is the minimum maintenance space required in the front, rear, left and right of the press machine.

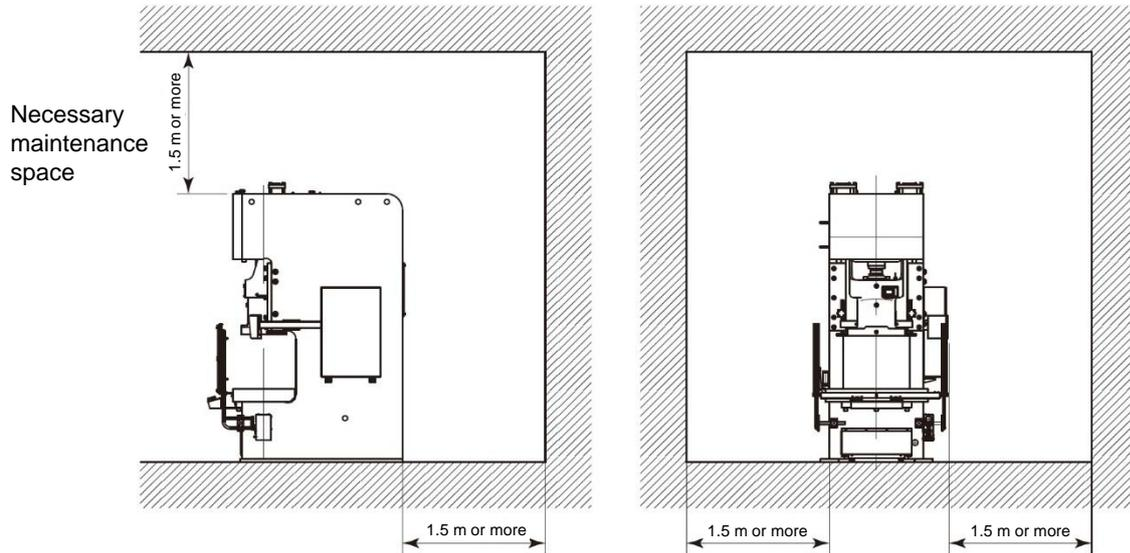

(Refer to the catalog for details since the machine dimensions differ according to the model and specifications of the machine.)

2. Protection examples

2-1. Basic protection method

In order to prevent the danger of being caught in the die, firstly prevent entry into the hazardous area, and if it is impossible, adopt a light curtain or the like to stop the press machine.

If insertion of workpieces or removal of processed parts cannot be automated, it is the basic protection that you do not need to put a part of your body into a hazardous area by using manual tools.

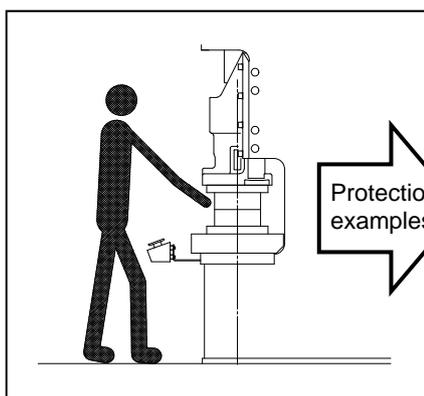

2-2. Measures against entry from outside (beyond upper limit) of protection range

Before installing a guard or safety device, you need to sufficiently consider the physique and working posture of workers.

You must determine the protection height so that a part of body does not reach the hazardous area beyond the upper limit of the protection range of guards or light curtain.

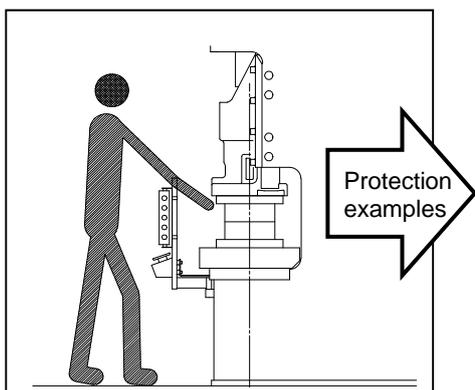

2-3. Measures against entry from outside (under lower limit) of protection range

Before installing a guard or safety device, sufficiently consider the physique and working posture of workers. If it is assumed that a part of body enters the hazardous area by going through under the lower limit of the guard range or the protection range of a light curtain, take measures such as completely shielding the working surface or furnishing a light curtain combined with a baffle plate.

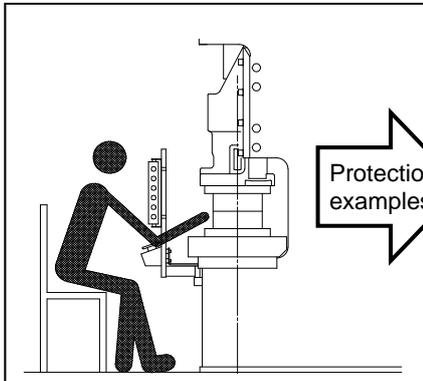

2-4. Measures against entry from outside (left or right side) of protection range

Even if the operation side is protected with a guard or a safety device, workers may enter from a position other than the front side for unsteady work such as adjustment or inspection. Also, you need to consider protection for assistant workers and third persons. Protect with a fixed guard or a light curtain even against the entry from the side of the machine.

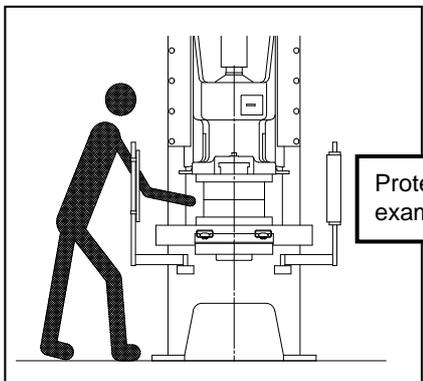

2-5. Measures against entry from outside (rear side) of protection range

You also have to assume that a third person may activate the machine when you are working inside the machine for adjustment or cleaning.

You also need to consider protection for assistant workers and third persons.

Protect with a fixed rear guard or a light curtain against the entry from the rear side and the inadvertent activation by a third person.

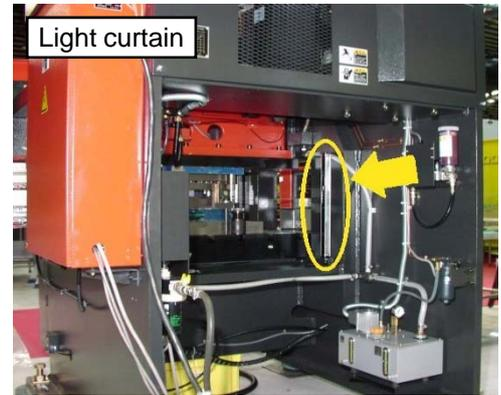
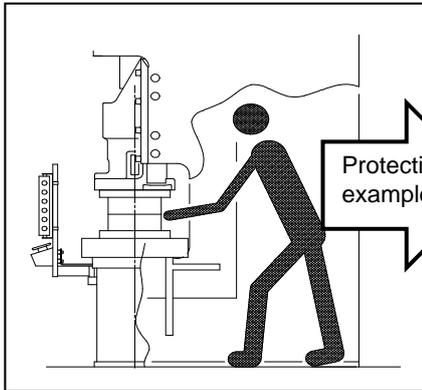

2-6. Measures against entry of part of body between bolster and light curtain

In order to prevent any gap between the light beam of the light curtain and the front end of the bolster that a part of body may enter, protect from such a gap with a baffle plate or a light curtain.

Such a gap must be less than 75 mm.

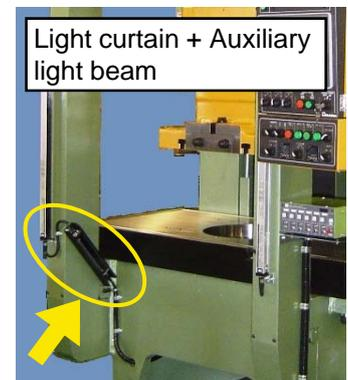
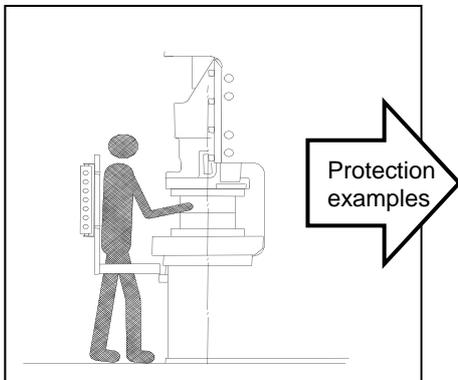

2-7. Protection from flying objects

Be sure to adopt a guard-type protection when flying of fragments due to breakage of the die is foreseeable. Flying of fragments is not limited toward the front. Be sure to consider protection of persons other than workers.

With automatic machines, an accident is likely to occur at setup more than in normal production.

It is recommended to adopt interlock which disables even jogging function when the guard is open.

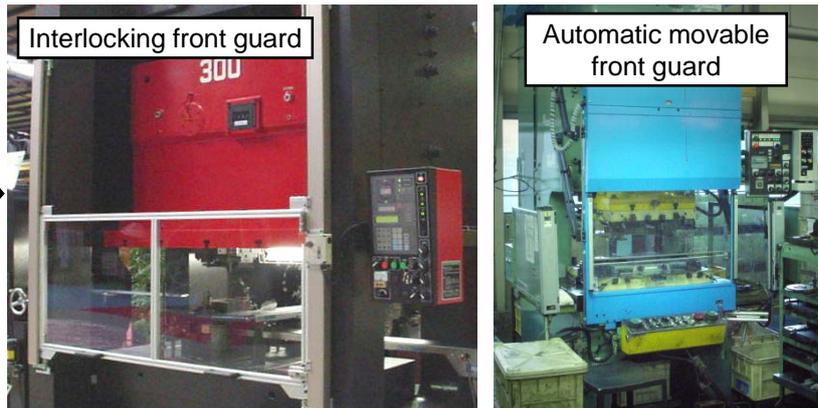
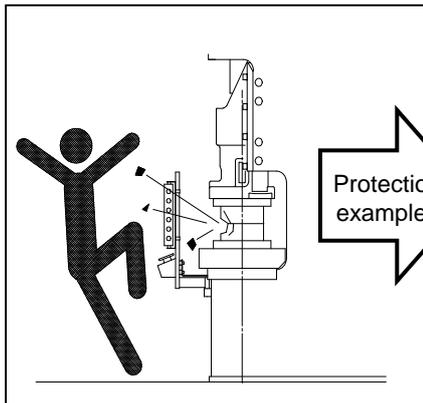

2-8. Measures against pinch hazard with knockout device

Other than the hazardous area created with the die, there are places where a part of your body is possibly pinched.

When using a mechanical knockout device, you need to consider the risk where a third person erroneously activates the machine during adjustment or a third person accidentally touches the machine while it operates.

If entry to the vicinity of the knockout device cannot be restricted, you need to increase the protection height of the side guard and the side light curtain.

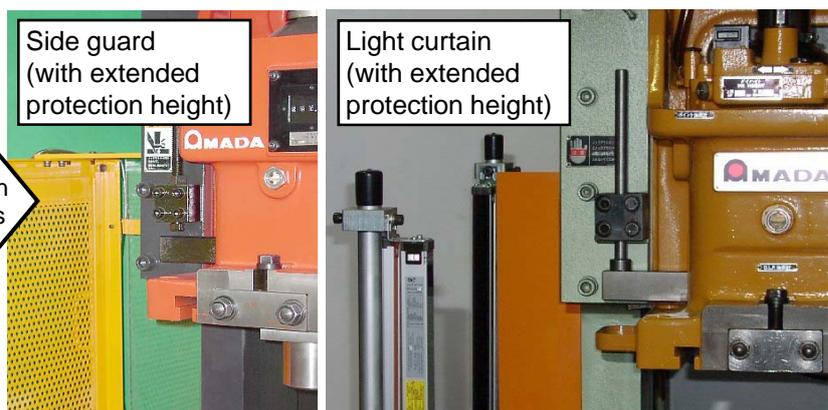
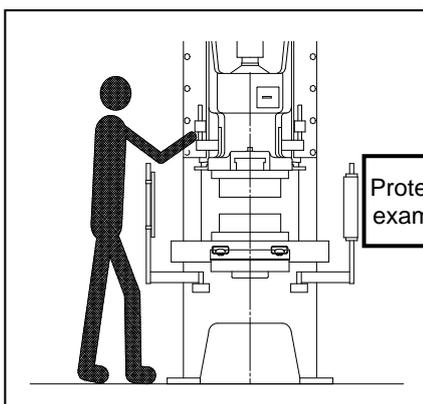

3. Other devices/functions

In order to use the press machine more safely, the following equipment and devices are furnished as standard features or available as options. Choose them according to the contents of your work.

3-1. Electrical enclosure main circuit breaker [Standard feature]



Opening the door of the electrical enclosure with the power on will lead to fatal accidents due to electric shock because of a high voltage.

The electrical enclosure main circuit breaker permits to open the door only after the power is turned off.

3-2. Simultaneous operation for jogging [Standard feature]

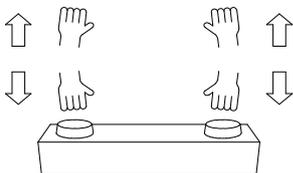

Since the slide operates only when the two-hand controls are pressed simultaneously within 0.5 seconds, dangerous work by one-hand operation is prevented.

3-3. Clutch brake solenoid valve with monitoring function [Standard feature]



Abnormality of the clutch brake solenoid valve is electrically sensed and notified.

3-4. Light curtain (2-light beam obstruction specification) [Option]



A normal light curtain stops the press when one light beam is obstructed, but a light curtain of the 2-light beam obstruction specification stops the press;

- when two consecutive light beams are obstructed, or
- when only the uppermost or lowermost light beam is obstructed.

The press does not stop even if one light beam is obstructed by the workpiece.

* This option is suitable for the work where a workpiece is passed from the light beam plane.

3-5. Flywheel brake [Option]



Stops the rotation of the flywheel within a short time.

Request for provision of accident information

On April 15, 2014, the Labour Standards Bureau of the Ministry of Health, Labour and Welfare issued the LSB Notification No. 0415-1 "Procedure for Promoting Provision of Disaster Information, etc., from Machine Users to Machine Manufacturers, etc."

The notification obligates machine manufacturers to clearly state contact points, contact methods and accident information and other contact items in instruction manuals, etc., and machine users to furnish information to machine manufacturers and to take measures for preventing the recurrence of accidents, etc., in coordination with machine manufacturers.

Following the notification, Amada intends to collect accident information from our customers and use it to prevent the recurrence of similar accidents with our machines and to promote greater safety in the design and manufacturing stages of our machines. We kindly ask for your cooperation.

(1) Contact point

Report accident information, etc., by telephone or otherwise to our sales office service center in your area.

(2) Information to be provided

Furnish to us accident information concerning the contact items described in the following accident report.

Accident report

Date reported	mm/dd/yy	● Overview of accident
Classification of accident:		Date and time of accident occurrence: mm/dd/yy
1. Occurrence or likelihood of injury or fatal accident		Approximately hh:mm
2. Occurrence or likelihood of fire accident		[Injury or fatal accident]
● Customer		Victim: 1. Operator
Company name (department name):		2. Other than operator ()
Name (position):		Sex (age): 1. Male 2. Female (xx years old)
Address:		Accident situation (body part and degree of injury):
Telephone number:		[Fire accident]
Fax number:		Ignition source and ignited material (if determinable):
E-mail address:		Burnt range:
● Amada machine used (Information stamped on serial plate)		Work and process leading to accident:
Model:		Usage of protective equipment:
Manufacture number:		Comment from customer:
Manufacture date:	mm/yy	



AMADA hopes that this safety guide book will help you to provide a safe workplace for your press machine operators.
If you have something to know about the safeguarding of press machines or need more information or proposals, contact AMADA.

AMADA PRESS SYSTEM CO., LTD.
200, Ishida, Isehara-shi, Kanagawa, Japan
+81-463-96-3321
<https://www.amp.amada.co.jp/en/>