

SH-8A

MEC 7-AXIS CNC SINGLE-POINT COILING MACHINE

For wire diameters of $\varnothing 0.1 \sim \varnothing 0.8$ mm

Equipped with torsion attachment and initial tension servo motor as standard, it is possible to form compression springs, torsion springs, as well as elliptical springs.

The 3D coiling point moves freely, improving operability and allowing high-speed production.

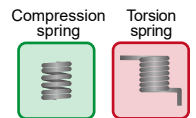

Features

7-axis control with an emphasis on operability

- The 7-axis control is equipped with feed, cut, pitch, outer coil diameter point, torsion, initial tension, and a MSD sensor as standard features.
- The standard MSD contact sensors allow for free length measurement. Servo motor control enables measurement in 0.001 mm increments. (Available as in capacitance length detector as optional.)
- The separation of the cut and torsion axes improves production speed and makes setting easier.
- Using the bender assist tool makes 3D torsion spring processing possible.

Support for IOT

The operating status of machine can be monitored through mobile phones or computers, and regular maintenance with preventive maintenance functions can contribute to improved production efficiency.

Improved operability with the MNO2 (MEC New Operation 2) programming software

- The MEC original MNO2 software easily organizes important statistics about the machine, including program flow, operating status of each axis, input/output, and jump, etc., as with our other spring machines.
- The coil number program allows to easily change feed, pitch, outer diameter, and initial tension on the advanced pitch diagram screen, making it easier to adjust basic coils.
- Cylinders, tapers, barrels, and double-taper springs can be processed just by inputting their specifications in the program. The taper of a spring can be fine adjusted easily with a numerical value between 0 and 100, such as bowl, straight, and mount type, by changing the taper coefficient.
- The automatic function of coil length correction based on the MSD sensor length measurement method, the multi-functional production manager system makes production easy to control.

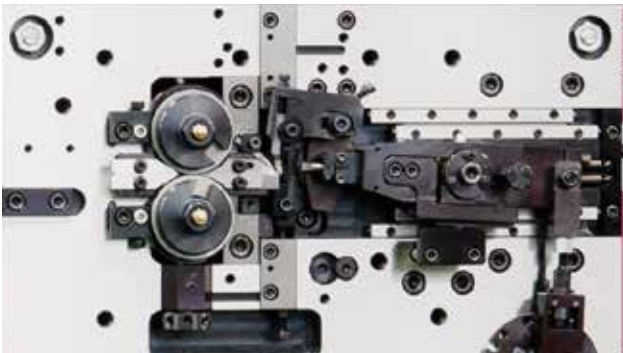

Coiling area

The torsion axis, with a newly designed crank mechanism, can now run in high speed. The initial tension servo is stored in the front plate.



Coil number program (cylindrical coils)

Greatly improved operability, with the easy-to-use navigation system and the touch screen, makes it easy to create programs and shortens setup time.

Specifications

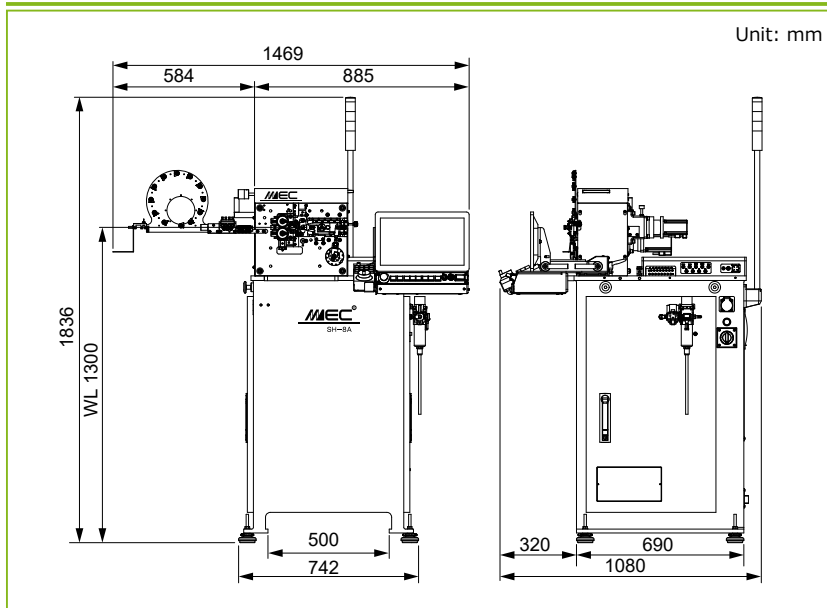

*Resolution: Program input unit, which does not represent accuracy.
Specifications are subject to change without notice for product improvement.

Machine name	SH-8A
Wire diameter	ø0.1 ~ ø0.8 mm
Outer coil diameter	ø20 mm
Index	D/d 4 or more
Feed axis*	0.0001 mm
Max feed speed	170 m/min
Cut axis*	0.001°
Pitch axis*	0.0001 mm
Point axis*	0.0001 mm
Torsion axis*	0.001°
Initial tension axis*	0.0001 mm
Arbor axis* (Optional)	0.0001 mm
Solenoid valves	4 pcs (Max 8 pcs)
Max air pressure	0.5 MPa
Power source	3-phase AC 200V, 15A
Net weight	380 kg
Control device	Windows
Software	MNO2
Display	15.6" Full HD touch screen
External memory	USB Thumb drive
Temperature	5 ~ 40°C

