

ES-1A

MEC 48-AXIS CNC SEGMENT-CONDUCTOR COIL PROCESSING MACHINE for xEV Motors

For wire materials of (w x h) 2 ~ 6 x 1 ~ 3 mm

**Specialized machine for processing up to 20 different types
of segment-conductor coils without changing setups.**



Segment-
conductor
coil



Features

Increased productivity through automation and reduced setup time

- The workpieces are moved for each process (feeding, straightening, peeling, bending, pressing) and divided into parts for processing. This newly developed rectangular copper wire bending and transfer system enable high-speed, high-precision production by overlapping each process.
- Up to 20 types of segment-conductor coils, all of which may be required for one EV motor, can be produced without any setup changes using only program operations.
- With common segment-conductor coils, we achieve an accuracy of 0.3 mm or less for the width between the coils, which affects the stator insertion pressure.
- In order to minimize the effect of the straightness of the wire on the bending angle, bending is performed using sensor measurements.
- A straightener-line machine specifically designed for rectangular copper wire makes it easy to process straight lines.
- By using the included TY-500AE uncoiler, setup is simple. Wire is fed out smoothly, reducing back tension that affects coil forming. In addition, the newly developed straightening mechanism removes residual stress in the rectangular copper wire and improves its straightness. This enables highly accurate processing.
- The unique circular transfer system mechanism shortens production takt time and saves installation space.

Processing process transfer diagram

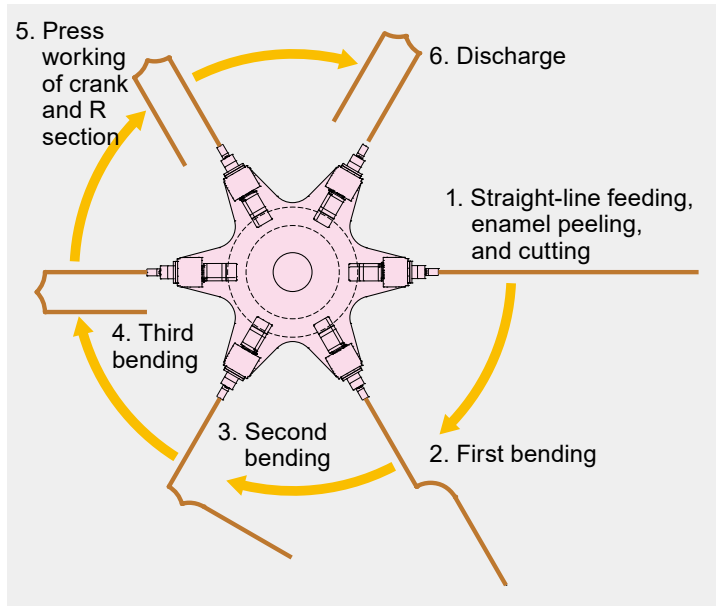

Specifications

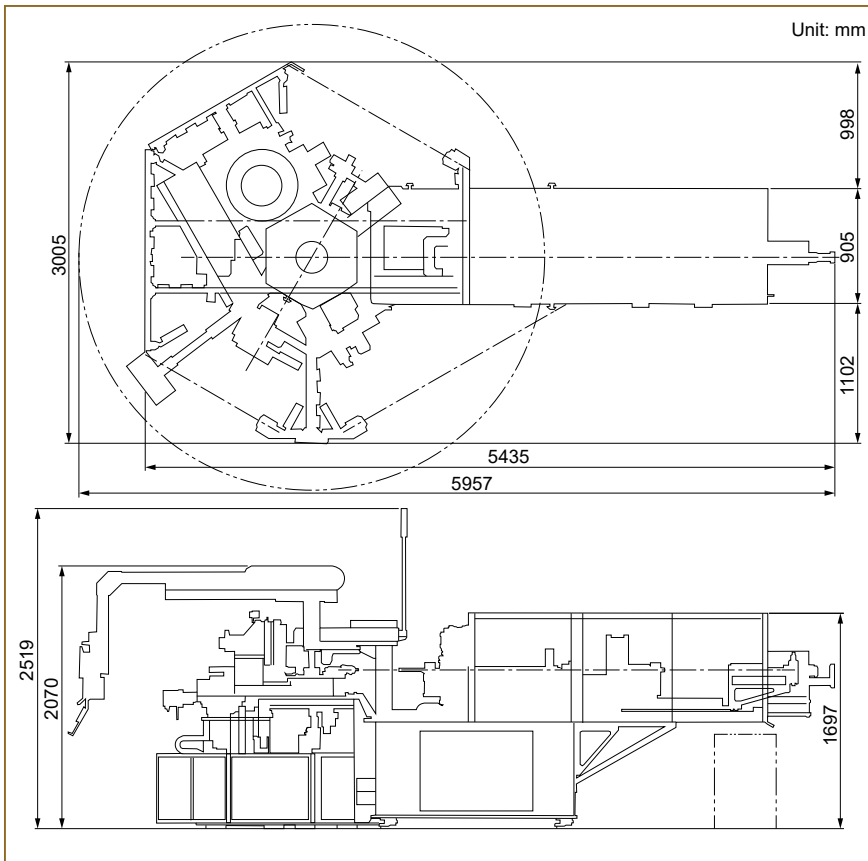

Machine name	ES-1A
Wire width	2 ~ 6 mm
Wire thickness	1 ~ 3 mm
Max. developed length	700 mm
Min. developed length	170 mm
Max. peel length	30 mm
Production rate	38 pieces/min
Bending correction	With
Setup for product changes	Automatic
Max air pressure	0.5 MPa
Power source	3-phase, AC200V 30A
Net weight	3,650 kg
Control device	Windows
Software	ES
Display	15.6" Full HD touch screen
External memory	USB Thumb drive
Temperature	5 ~ 40°C

Specifications are subject to change without notice for product improvement.

