

CLS-10A

MEC 7-AXIS CNC EXTENSION SPRING MACHINE

For wire diameters of $\varnothing 0.2 \sim \varnothing 1.0$ mm

Synchronized control of coiling and hook end raising processes achieves stable continuous high-speed production.

The automatic programming and automatic outer coil diameter correction functions of the MPS (MEC Program System) make it easy to process various hook shapes.



Extension
spring



Features

High-efficiency production with synchronized control

Synchronized control linked to the extension spring processing can simultaneously process functions such as coiling, raising hooks on both ends, and discharging, allowing for stable high-speed production.

Improved operability with MEC Program System MPS

- The program editing function has greatly evolved, making it easy to create programs with various hook shapes and reducing setup time.
- Due to the servo motor controlling the coiling point, the program adjusts initial tension and diameter, forming for wires of different diameter, and U hooks.
- The transfer unit controlling the clamp by programming enables it to stop before crashing when swinging.
- Coil end is measured by the coil end alignment sensor. Outer coil diameter can be adjusted automatically.
- The MPS easily organizes important statistics about the machine, including program flow, operating status of each axis, inputs/outputs, jump, etc., as with our other spring machines.
- The multi-function production management system gives easy-to-control production.



MPS main program screen

Gives a comprehensive view of what is happening with the spring machine, allowing easy checking and adjustment of the specification pattern program and at-a-glance view of multiple axes' statistics.

Improved quality with dual feed roller and 7-axis control

- Due to the introduction of a dual feed roller, feed pressure load applied to the wire is reduced, making stable coiling possible.
- The 7-axis control gives easy control over feed, point, initial tension, cam, transfer, and clamp. The camshaft drives pitch, arbor front/rear, cut, front/rear tooling, and tooling slides.
- The cutting tool is able to move backward to prevent long stroke overshoot.
- The tooling unit raises both coil ends to form hooks in one maneuver. The angle and spaces clearance between hook and coil are equally the same on opposite sides, with high accuracy.
- The tooling unit consists of a base, squeeze, hook, end press, and off-bending tools. The end press and off-bending tools adjust automatically, making it easier to form German and U hooks.

Main option

The automatic measurement system "IS-2X" by image processing and various laser sensor units enable advanced measurement of outer coil diameter, hook shape, space, etc.

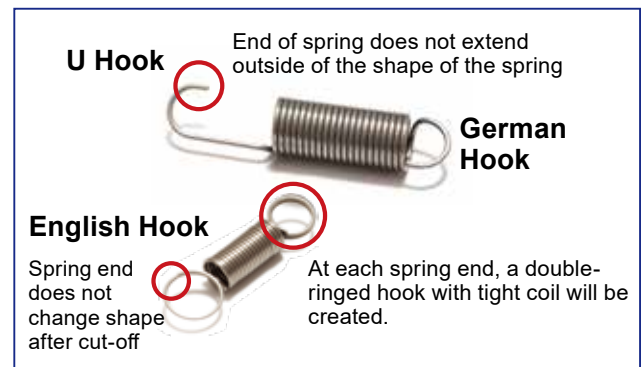

The program makes it easy to adjust extension springs.

Specifications

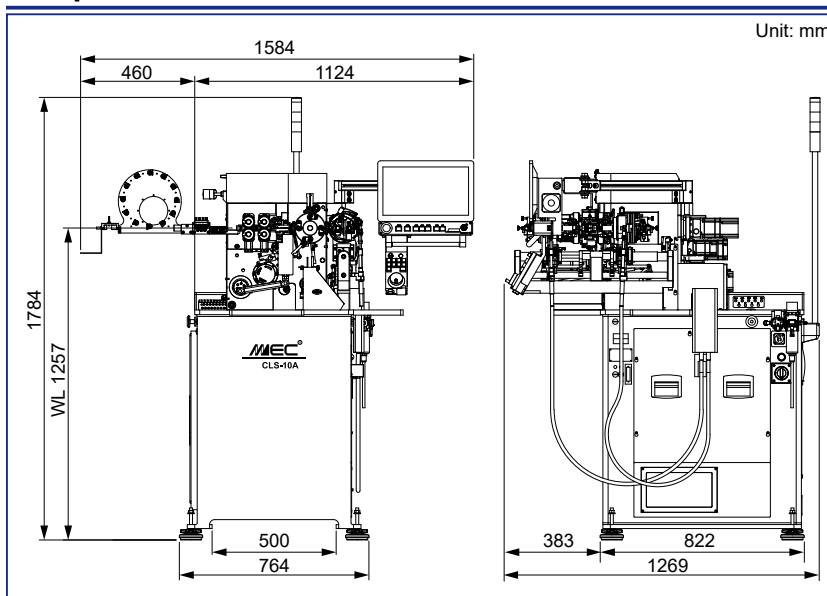

*1: May vary depending upon wire diameter.

*2: Maximum is 150 mm when using the optional holder.

*3: Resolution: Program input unit, which does not represent accuracy.

! Before using those products, please read the operator's manual carefully and follow all applicable instructions.

Machine name	CLS-10A
Wire diameter	ø0.2 ~ ø1.0 mm
Outer coil diameter	ø1.5 ~ ø12 mm
Index*1	D/d 4 or more
Closed coil length*2	Wire ø x 12, ~ 100 mm
Max U hook length	15 mm
Feed axis*3	0.001 mm
Max feed speed	120 m/min
Point axis*3	0.001 mm
Torsion axis*3	0.001°
Initial tension axis*3	0.001°
Cam axis*3	0.001°
Transfer axis*3	0.001°
Clamp axis*3	0.001°
Max solenoid valves	8 pcs (Installed)
Air pressure	0.3 ~ 0.5 MPa
Power source	3-phase, AC 200V, 15A
Net weight	600 kg
Control device	Windows
Software	MPS
Display	15.6" Full HD touch screen
External memory	USB Thumb drive
Temperature	5 ~ 40°C

- Use of this product requires safeguard measures to suit your work.
- Specifications, appearance, and equipment are subject to change without notice for improvement and other purposes.
- Photos may include options.
- The specifications described in this catalogue are for the Japanese market. Please ask your sales person for details.

